

Table of Contents

Introduction to Your LaCie 500 Series LCD Monitor	8
500 Series LCD Monitor Features.....	8
Box Content	9
Installing Your LaCie 500 Series LCD Monitor	10
Using Your LaCie 500 Series LCD Monitor.....	13
Physical Adjustments	13
Raise and Lower the Monitor Screen.....	13
Screen Tilt.....	13
Screen Rotation.....	14
Swivel 14	
Remove the Monitor Stand for Mounting	15
Flexible Arm Installation	16
OSD (On-Screen Display) Control Menu Functions	17
Brightness/Contrast Controls	18
Auto Adjust (Analog Input Only).....	18
Image Controls.....	19
Color Control Systems.....	20
Tools	21
Menu Tools.....	23
Information	24
OSD Warnings.....	25
Advanced Menu Functions.....	25
Using the Picture Mode Function.....	36
Using the Auto Brightness Function.....	37
Troubleshooting	39
Contacting Customer Support.....	41
LaCie Technical Support Contacts.....	42
Warranty Information.....	43

Copyrights

Copyright © 2011 LaCie. All rights reserved. No part of this publication may be reproduced, stored in a retrieval system, or transmitted in any form or by any means, electronic, mechanical, photocopying, recording or otherwise, without the prior written consent of LaCie.

Trademarks

Apple, Mac, and Macintosh are registered trademarks of Apple Inc. Microsoft, Windows XP, Windows Vista, and Windows 7 are registered trademarks of Microsoft Corporation. Adobe® is a registered trademark or trademark of Adobe Systems Incorporated in the U.S. and/or other countries. Other trademarks mentioned in this manual are the property of their respective owners.

Changes

The material in this document is for information only and subject to change without notice. While reasonable efforts have been made in the preparation of this document to assure its accuracy, LaCie assumes no liability resulting from errors or omissions in this document, or from the use of the information contained herein. LaCie reserves the right to make changes or revisions in the product design or the product manual without reservation and without obligation to notify any person of such revisions and changes.

FCC Declaration of Conformity:



NOTE: This equipment has been tested and found to comply with the limits for a Class B digital device, pursuant to Part 15 of the FCC Rules. These limits are designed to provide reasonable protection against harmful interference in a residential installation. This equipment generates, uses and can radiate radio frequency energy and, if not installed and used in accordance with the instructions, may cause harmful interference to radio communications. However, there is no guarantee that interference will not occur in a particular installation. If this equipment does cause harmful interference to radio or television reception, which can be determined by turning the equipment off and on, the user is encouraged to try and correct the interference by one or more of the following measures:

- ❖ Reorient or relocate the receiving antenna.
- ❖ Increase the separation between the equipment and receiver.
- ❖ Connect the equipment into an outlet on a circuit different from that to which the receiver is connected.
- ❖ Consult the dealer or an experienced radio/TV technician for help.
- ❖ Use only shielded cables to connect I/O devices to this equipment.

Use the attached specified cables with the LaCie 500 Series color monitor so as not to interfere with radio and television reception.

1. The power supply cord you use must have been approved by and comply with the safety standards of U.S.A. and meet the following condition.

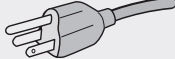
Power supply chord	Non shield type, 3-conductor
Length	2.0 m
Plug shape	 (USA)

2. Please use the supplied shielded video signal cable, 15-pin mini D-SUB to DVI-A cable or DVI-D to DVI-D cable. Use of other cables and adapters may cause interference with radio and television reception.

U.S. Responsible Party: LaCie, LTD

Address: 22985 NW Evergreen Pkwy
Hillsboro, OR 97124

Tel. No.: (503) 844-4503



We, LaCie, solemnly declare that this product conforms to the following European directives: 2004/108/EC (EMC), and 2006/95/EC (Safety)

LaCie S.A.
33 Bld du Général Martial Valin
75015 Paris
France

CAUTION: Modifications not authorized by the manufacturer may void the user's authority to operate this device.

CAUTION: A shielded-type power cord is required in order to meet FCC emission limits and also to prevent interference to the nearby radio and television reception. It is essential that only the supplied power cord be used.

Safety Precautions and Maintenance

- ❖ DO NOT OPEN THE MONITOR. There are no user serviceable parts inside and opening or removing covers may expose you to dangerous shock hazards or other risks. Refer all servicing to qualified service personnel.
- ❖ Do not spill any liquids into the cabinet or use your monitor near water.
- ❖ Do not insert objects of any kind into the cabinet slots, as they may touch dangerous voltage points, which can be harmful or fatal or may cause electric shock, fire or equipment failure.
- ❖ Do not place any heavy objects on the power cord. Damage to the cord may cause shock or fire.
- ❖ Do not place this product on a sloping or unstable surface, as the monitor may fall, causing serious damage.
- ❖ Do not place any objects onto the monitor and do not use the monitor outdoors.
- ❖ The inside of the fluorescent tube located within the LCD monitor contains mercury. Please follow the bylaws or rules of your municipality to dispose of the tube properly.
- ❖ Do not bend power cord.
- ❖ Do not use monitor in high temperatures, humid, dusty, or oily areas.
- ❖ Do not cover vent on monitor.

Immediately unplug your monitor from the outlet and refer servicing to qualified personnel under the following conditions:

- ❖ When the power supply cord or plug is damaged.
- ❖ If liquid has been spilled, or objects have fallen into the monitor.
- ❖ If the monitor has been exposed to rain or water.
- ❖ If the monitor has been dropped or the cabinet damaged.
- ❖ If the monitor does not operate normally by following operating instructions.
- ❖ If glass is broken, handle with care.
- ❖ If the monitor and its glass are broken, do not come in contact with the liquid crystal and handle with care.

Please pay heed to the following guidelines:

- ❖ Allow adequate ventilation around the monitor so that heat can properly dissipate. Do not block ventilated openings or place the monitor near a radiator or other heat sources. Do not put anything on top of monitor.
- ❖ The power cable connector is the primary means of detaching the system from the power supply. The monitor should be installed close to a power outlet which is easily accessible.
- ❖ Save packaging for transporting. When moving the monitor, handle with extreme care.
- ❖ Please be aware that LCD Technology may experience a phenomenon known as Image Persistence. Image Persistence occurs when a residual impression or, "ghost", of a previous image remains visible on the screen. Unlike CRT monitors, image persistence is not permanent for LCD. However, constant images being displayed for a long period of time should be avoided. To alleviate image persistence, turn off the monitor for as long as the previous image was displayed. For example, if an

image was left static for one hour, the monitor should be turned off for one hour to allow the impression to fade away.

- ❖ When operating the LaCie 500 Series LCD Monitor with a 220-240V AC power source in Europe, use the power cord provided with the monitor.
- ❖ In the UK, a BS approved power cord with a moulded plug has a Black (five Amps) fuse installed for use with this equipment.
- ❖ If a power cord is not supplied with this equipment please contact your supplier.
- ❖ When operating the LaCie 500 Series LCD Monitor with a 220-240V AC power source in Australia, use the power cord provided with the monitor. If a power cord is not supplied with this equipment please contact your supplier.
- ❖ For all other cases, use a power cord that matches the AC voltage of the power outlet and has been approved by and complies with the safety standard of your particular country.

Health and Ergonomic Precautions

Correct placement and adjustment of the monitor can reduce eye, shoulder, and neck fatigue. Check the following when you position the monitor:

- ❖ For optimum performance, allow 20 minutes for warm-up.
- ❖ Adjust the monitor height so that the top of the screen is at, or slightly below, eye level. Your eyes should look slightly downward when viewing the middle of the screen.
- ❖ Position your monitor no closer than 40 cm and no further away than 70 cm from your eyes. The optimal distance is 50 cm.



To maximize ergonomic benefits, LaCie recommends the following:

- ❖ Adjust the brightness until the background raster disappears.
- ❖ Do not position the contrast control to its maximum setting.
- ❖ Use the preset size and position controls with standard signals.
- ❖ Use the preset color setting.
- ❖ Use non-interlaced signals with a vertical refresh rate between 60-75 hz.

- ❖ Rest your eyes periodically by focusing on an object at least 20 feet away. Blink often.
- ❖ Position the monitor at a 90° angle to windows and other light sources to minimize glare and reflections. Adjust the monitor tilt so that ceiling lights do not reflect on your screen.
- ❖ If reflected light makes it hard for you to see your screen, use an anti-glare filter.
- ❖ Clean the LCD monitor surface with a lint-free, non-abrasive cloth. Avoid using any cleaning solution or glass cleaner!
- ❖ Adjust the monitor's brightness and contrast controls to enhance readability.
- ❖ Use a document holder placed close to the screen.
- ❖ Position whatever you are looking at

most of the time (the screen or reference material) directly in front of you to minimize turning your head while you are typing.

- ❖ Avoid displaying fixed patterns on the monitor for long periods of time to avoid image persistence (after-image effects or "ghosting").

- ❖ Do not use primary color blue on a dark background, as it is difficult to see and may produce strain the eyes toward insufficient contrast.



Within the European Union

EU-wide legislation, as implemented in each Member State, requires that waste electrical and electronic products carrying the mark (left) must be disposed of separately from normal household waste. This includes monitors and electrical accessories, such as signal cables or power cords. When you

need to dispose of your LaCie display products, please follow the guidance of your local waste authority. For further information on the disposal of your monitor, please ask the shop where you purchased the product or, if applicable, follow any agreements made between yourself and LaCie.

The mark on electrical and electronic prod-

ucts only applies to the current European Union Member States.

Outside the European Union

If you wish to dispose of used electrical and electronic products outside the European Union, please contact your local authority in order to comply with the correct waste removal laws.

Manufacturer's Recycling and Energy Information

LaCie is strongly committed to environmental protection and sees recycling as one of the company's top priorities in trying to minimize the burden placed on the environment. We are engaged in developing environmentally friendly products, and always strive to help define and comply with the latest ecological standards.

Recycling programs information:

Sweden - <http://www.recycling.se>

Germany - <http://www.recyclingpartner.de/>

Holland - <http://www.mirec.nl/>

Japan - <http://www.diarcs.com/>

Energy saving:

This monitor features an advanced energy saving capability. When a VESA Display Power Management Signaling Standard (DPMS) signal is sent to the monitor, the Energy Saving mode is activated. The mon-

itor enters a single Energy Saving mode.

Mode	Power consumption	LED color
Normal Operation (with option)	Approx. 125W	Blue
Normal Operation (at TCO testing)	Approx. 65W	Blue
Energy Saving Mode	Less than 1W	Amber
POWER MANAGER	Less than 1W	Unlit



Monitor Specifications

526 LCD Monitor	
Technology:	H-IPS POL
Diagonal display:	25.5" (64.9 cm)
Active Display:	550 (H) x 344 (V) mm
Resolution:	Some systems may not support all modes listed. 720 x 400* at 70 Hz to 85 Hz; 640 x 480* at 60 Hz to 85 Hz; 800 x 600* at 56 Hz to 85 Hz; 832 x 624* at 75 Hz; 1024 x 768* at 60 Hz to 85 Hz; 1152 x 864* at 70Hz to 85 Hz; 1152 x 870* at 75 Hz; 1280 x 960* at 60 Hz; 1280 x 1024* at 60 Hz to 85 Hz; 1600 x 1200* at 60 Hz to 75 Hz ;1200 x 1920* at 60 Hz 1920 x 1200 at 60 Hz – LaCie recommends this resolution for optimal display performance. The LaCie 526 supports HDTV resolutions (1920x1080p@50Hz, 1920x1080p@60Hz, 1280x720p@60Hz, 1280x720p@50Hz) as well as 720x480p@60Hz and 720x576p@50Hz
Pixel pitch:	0.287 mm, 89 PPI
Gamut:	102% NTSC
Color depth:	16,777,216
Gamma correction:	12 bit with 16 bit precision
Luminance:	320 cd/m ² (typ.)
Contrast ratio:	1000:1 (typical)
Response time:	Rise time + Fall time : 16ms(typical) 8ms G to G
Viewing angles:	Left/Right ±89°, Up/Down ±89°
Connections:	Mini D-sub 15 pin, DVI-I (analog or digital), DVI-D (digital)
Power consumption:	111W (typical)
In power save mode	< 1 W
Weight:	9.4 kg
Weight with stand:	12.8 kg
Ergonomy:	Up/down: 30° to -5°; left/right: 170° to 170°; clockwise: 90°; height adjustment: 150 mm
Operating Temp.:	5°C to 35°C/41°F to 95°F
Humidity:	30% to 80%
Altitude:	0 to 10,000 feet / 0 to 3,048 m
Certifications:	CE, FCC-B, TÜV-Ergonomie, TÜV-GS, GOST-R, c-UL, UL, VESA DDC 2B, DDC-CI
	*Interpolated Resolutions: When resolutions are shown that are lower than the pixel count of the LCD module, text may appear different. This is normal and necessary for all current flat panel technologies when displaying non-native resolutions full screen. In flat panel technologies, each dot on the screen is actually one pixel, so to expand resolutions to full screen, an interpolation of the resolution must be performed.

1. Introduction to Your LaCie 500 Series LCD Monitor

Thank you for purchasing the LaCie 500 Series LCD Monitor. Designed for serious graphics professionals, this advanced line of LCD monitors features 12-bit gamma correction to meet the most stringent demands for color accuracy and control.



1.1. 500 Series LCD Monitor Features

- ❖ **Large 25.5" diagonal size and wide 16:10 format** enhances productivity by reducing the need for scrolling through documents and switching windows. The wide aspect ratio allows full 1:1 scale display of two full pages with additional space for application palettes and toolbars.
- ❖ **High 1920x1200 resolution and HDCP Content Protection technology** is ideal for high resolution graphics and video applications.
- ❖ **Wide-Gamut H-IPS POL panel technology** offers an industry-leading 102% NTSC Gamut that allows the LaCie 500 series monitors to display a wide range of vibrant colors previously unattainable by LCD monitors. When used in a color-managed environment, this offers the benefit of an even closer match between captured, displayed, and printed colors. This technology offers an excellent balance between contrast (1000:1), brightness (320 cd/m² typ.), and expansive viewing angles of 178°.
- ❖ **Improved uniformity:** Each panel is individually tested at the factory and corrected to ensure that brightness and chromaticity are uniform across the screen.
- ❖ **ColorKeeper Backlight Stabilizer:** The LaCie 526 monitor has an embedded sensor that analyzes the brightness and chromaticity of its backlight in real time. A feedback mechanism then uses this information to continuously adjust the backlight and panel to ensure stable monitor brightness and color.
- ❖ **12-bit Gamma Correction:** The embedded Integrated Circuit enables a genuine hardware calibration of the monitor. The 12-bit Gamma Correction tables (16 bits precision) allow an optimal display of color gradients.
- ❖ **Ergonomic stand** enables height swivel tilt and pivot adjustments.
- ❖ **VESA-100 interface:** The Monitor can be connected to any VESA 100 compatible attachment.
- ❖ **Portability handle and quick-release stand** make your LaCie 500 Series Monitor easy to carry.

1.2. Box Content

Your LaCie 500 Series LCD Monitor box should contain the monitor and accessories as follows:

1. LaCie 500 Series LCD Monitor with tilt/swivel/pivot/height adjustable stand
2. easyHood
3. US power cord
4. CE power cord
5. Screws (optional for mounting the monitor to a flexible arm)
6. Cable cover
7. Video signal cable (15-pin mini D-SUB male to DVI-A)
8. Video signal cable (DVI-D to DVI-D cable)
9. LaCie Utilities CD-ROM (includes the User Manual, Monitor ICC Profiles and blue eye pro calibration software)
10. Quick Install Guide
11. Cleaning Cloth

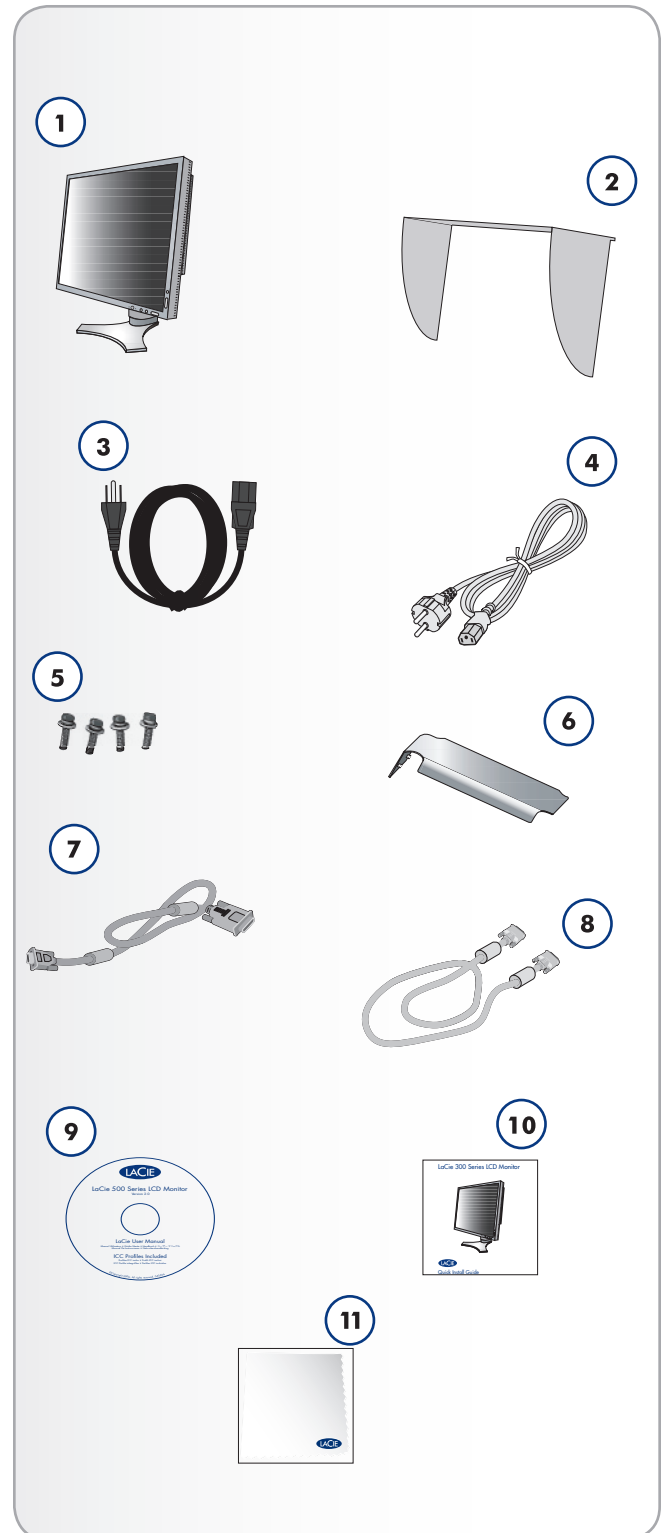

2. Installing Your LaCie 500 Series LCD Monitor

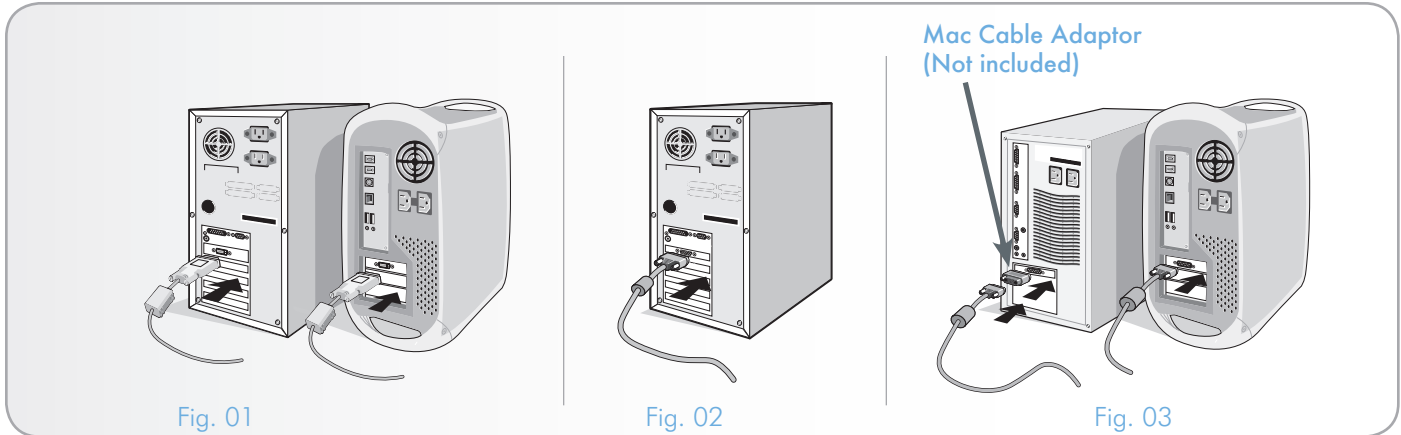

To attach the LCD monitor to your system, follow these instructions:

1. Turn off the power to your computer.
2. For the PC or Mac® with DVI digital output: attach the DVI signal cable to the display interface of your system (Fig. 01). Tighten all screws.
3. For the PC with analog output: attach the 15-pin mini D-SUB to DVI-A signal cable to the display interface of your system (Fig. 02).
4. For the Mac with analog output: first connect the Macintosh cable adapter (furnished separate from LaCie) to the computer display interface. Second, attach the 15-pin mini D-SUB signal cable to the Macintosh cable adapter (Fig. 03).

TECHNICAL NOTE: Some Macintosh systems do not require a Macintosh cable adapter.

continued on next page >>

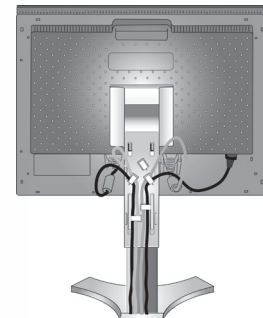
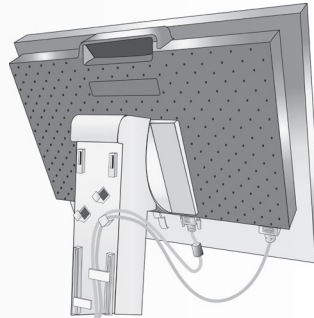
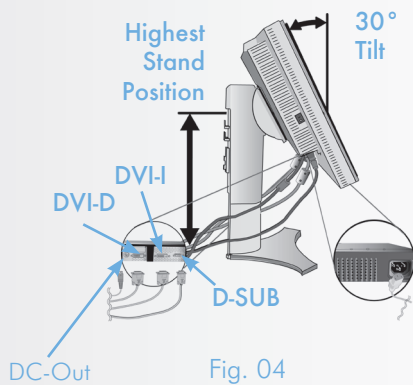

5. Place hands on each side of the monitor to tilt the LCD panel to a 30-degree angle and gently tilt in an upward direction to the highest position (Fig. 04).
6. Attach all cables to their appropriate interfaces (Fig. 04).
7. To keep the cables neatly organized, place them into the cable management system that is built into the stand.
 - ❖ Place the D-SUB cable (not included) and the power cable into the specific hooks as indicated (Fig. 05).
 - ❖ Place the DVI cable and the 15-pin mini D-SUB to DVI-A cable into the hooks as indicated (Fig. 06).
 - ❖ When using the monitor in Portrait mode, place the DVI cable and the 15-pin mini D-SUB to DVI-A cable into the hooks as indicated (Fig. 07).
8. Make sure all cables are resting flat against the stand (Fig. 06). Please provide room for Tilting, Rising, and Lowering the monitor screen as well as screen rotation when you manage cables.

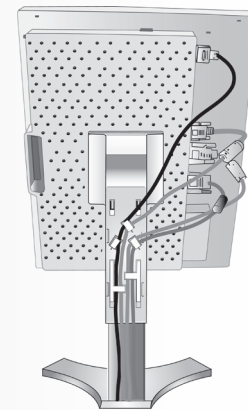

continued on next page >>

CAUTION: Incorrect cable connections may: result in irregular operation, damage display quality/components of LCD module, and/or shorten the module's life.

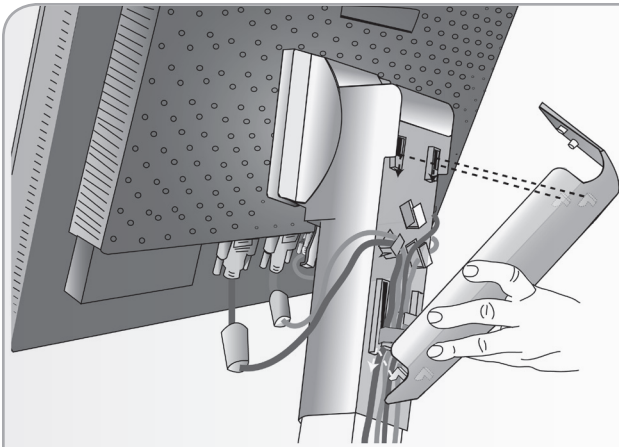

Fig. 08

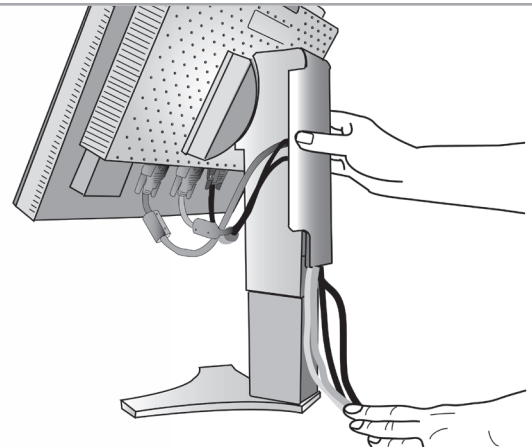

Fig. 09

7. Hold all cables firmly and place the cable cover onto the stand. To remove the cable cover, lift the cover off as shown in Fig. 08.
8. Connect one end of the power cord to the AC inlet on the back of the monitor and the other end to the power outlet.
9. The Vacation Switch on the left side of the monitor must be turned on in order to use the front power button. It is best to leave the Vacation Switch on all the time save for lengthy periods of inactivity. Use the front power button to turn on the monitor (Fig. 10) before starting the computer.

TECHNICAL NOTE: The Vacation Switch is a true ON/OFF switch. If this switch is in the OFF position, the monitor cannot be turned on using the front button. DO NOT adjust the Vacation Switch repeatedly.

10. No-touch auto adjust automatically tunes the monitor to optimal settings upon initial setup for most timings. For further adjustments, use the following OSD (on-screen display) controls:

- ❖ Auto Contrast (Analog input only)
- ❖ Auto Adjust (Analog input only)

Refer to [4. OSD \(On-Screen Display\) Control Menu Functions](#) for a full description of the OSD controls.

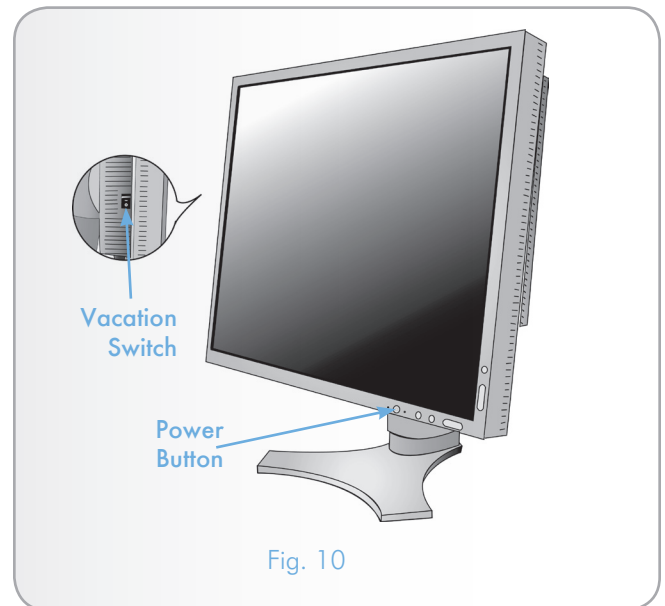

Fig. 10

TECHNICAL NOTE: Please refer to [Safety Precautions and Maintenance](#) for proper selection of an AC power cord.

3. Using Your LaCie 500 Series LCD Monitor

3.1. Physical Adjustments



Fig. 11



Fig. 12

3.1.1. Raise and Lower the Monitor Screen

The monitor may be raised or lowered in either Portrait or Landscape modes.

To raise or lower the screen, place hands on each side of the monitor and lift or lower to the desired height (Fig. 11 and Fig. 12).

TECHNICAL NOTE: Handle with care when raising, lowering, and tilting the monitor screen.

3.1.2. Screen Tilt

Grasp the top and bottom sides of the monitor screen with your hands and adjust the tilt as desired (Fig. 13).

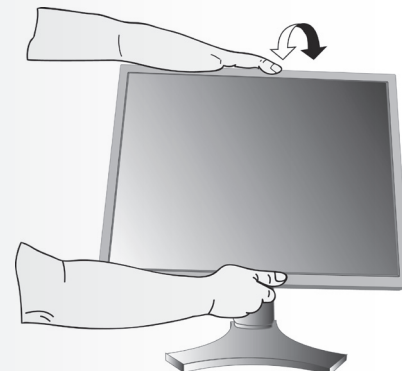
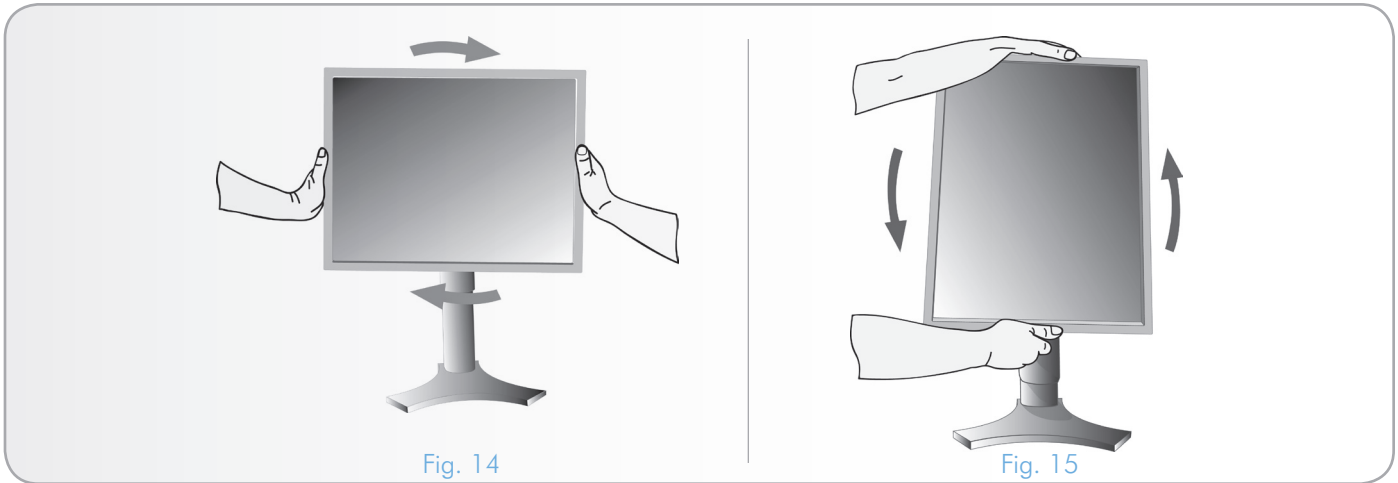

Fig. 13



3.1.3. Screen Rotation

Before rotating, the screen must be raised to its highest level in order to avoid an accidental fall and pinching your fingers. To raise the screen, place your hands on each side of the monitor and lift to the highest position (Fig. 12).

To rotate the screen, place hands on each side of the monitor and turn clockwise from Landscape to Portrait or counterclockwise from Portrait to Landscape (Fig. 14 and Fig. 15). To adjust the OSD menu between Landscape and Portrait modes, refer to 4. OSD (On-Screen Display) Control Menu Functions.

Mac Users

Portrait mode may be adjusted in System Preferences > Displays. Select the Rotate pull down menu, then 90°.

PC Users

Please regard the manual for your video board to determine how best to make the adjustment to Portrait Mode. If your video board does not provide the best solution, PivotPro offers software for Portrait Displays (LaCie is not responsible for any software provided by a third-party):

www.portrait.com

3.1.4. Swivel

Grasp both sides of the monitor screen with your hands and adjust the swivel as desired (Fig. 16).

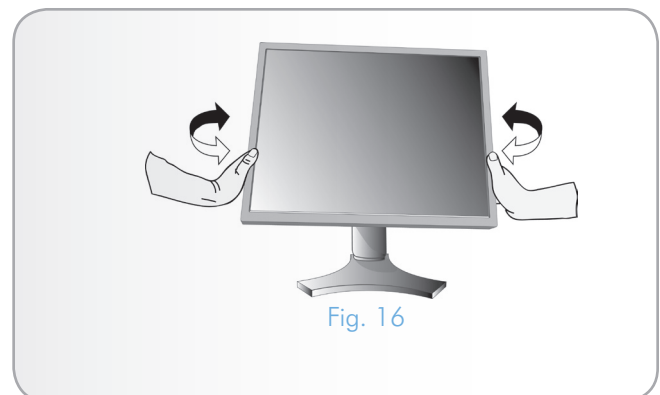

3.1.5. Remove the Monitor Stand for Mounting

To prepare the monitor for mounting:

1. Disconnect all cables.
2. Place hands on each side of the monitor and lift it to the highest position (Fig. 12).
3. Place monitor face down on a non-abrasive surface (Fig. 17).

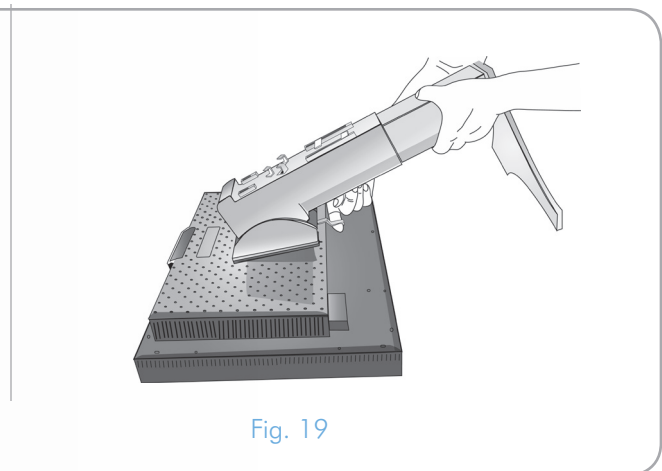
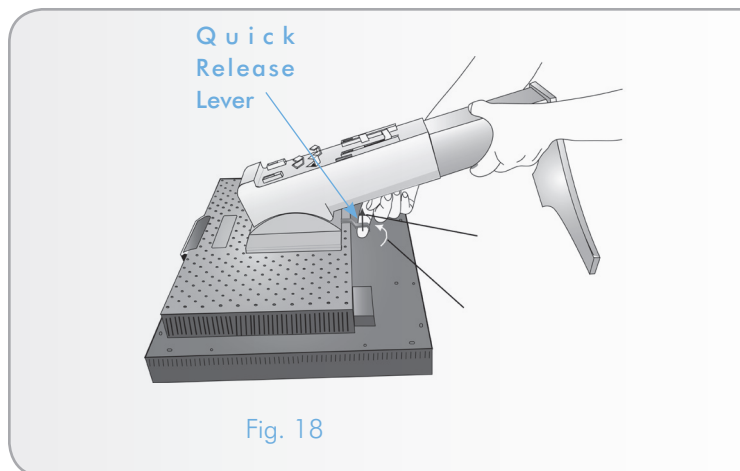
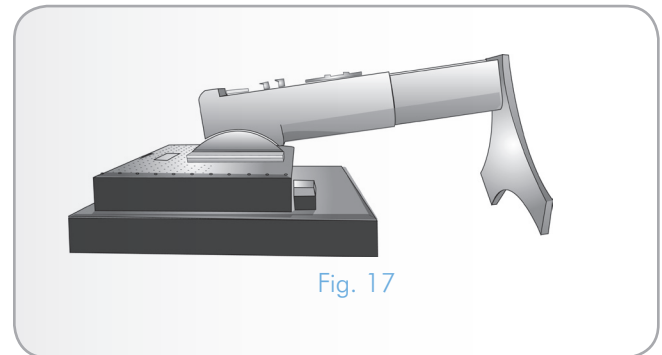

4. Place one hand around the base and one hand on the Quick Release Lever. Move the Quick Release Lever to the right, as indicated by the arrows (Fig. 18).
5. Lift the bottom of the stand to unhook it from the monitor (Fig. 19). The monitor is now ready for mounting.

TECHNICAL NOTE: Use only VESA-compatible alternate mounting methods (100 mm pitch).

IMPORTANT INFO: Please handle with care when removing the monitor stand.

3.1.6. Flexible Arm Installation

This LCD monitor is designed for use with a flexible arm. Follow the following steps:

1. See section 3.1.5. [Remove the Monitor Stand for Mounting](#) for instructions on how to remove the stand.
2. To attach the LaCie monitor to a flexible arm, use the four screws that were removed in 3.1.5. [Remove the Monitor Stand for Mounting](#) (Fig. 20).

IMPORTANT INFO: When mounting, use **ONLY** the screws that are included with your LaCie monitor to avoid any damage to the monitor and/or the stand. To meet the safety requirements, the monitor must be mounted to a flexible monitor arm that guarantees the stability of its weight. LaCie is not responsible for third-party flexible monitor arms or the damage that may be incurred when using a flexible monitor support arm with a LaCie monitor.

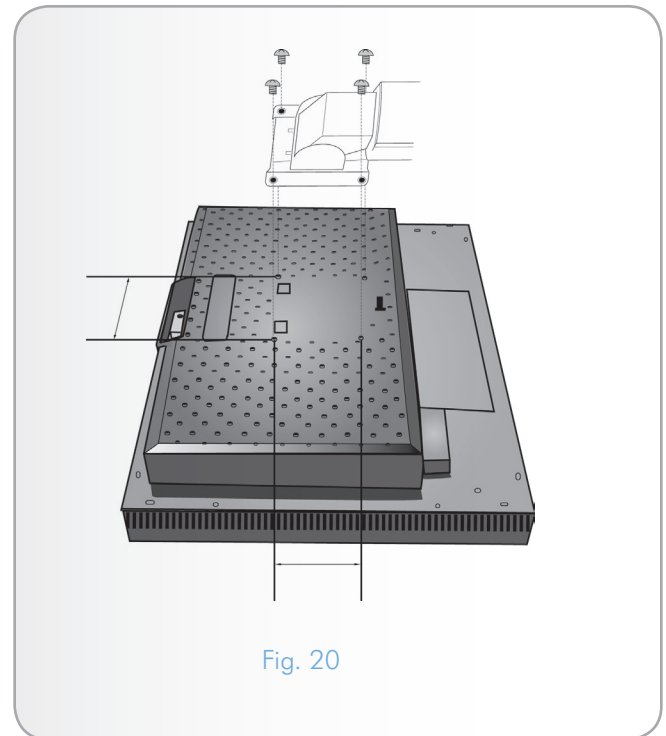

4. OSD (On-Screen Display) Control Menu Functions

To access the OSD menu, press MENU. To change the signal input, press SELECT.

TECHNICAL NOTE: The OSD must be closed in order to change the signal input.

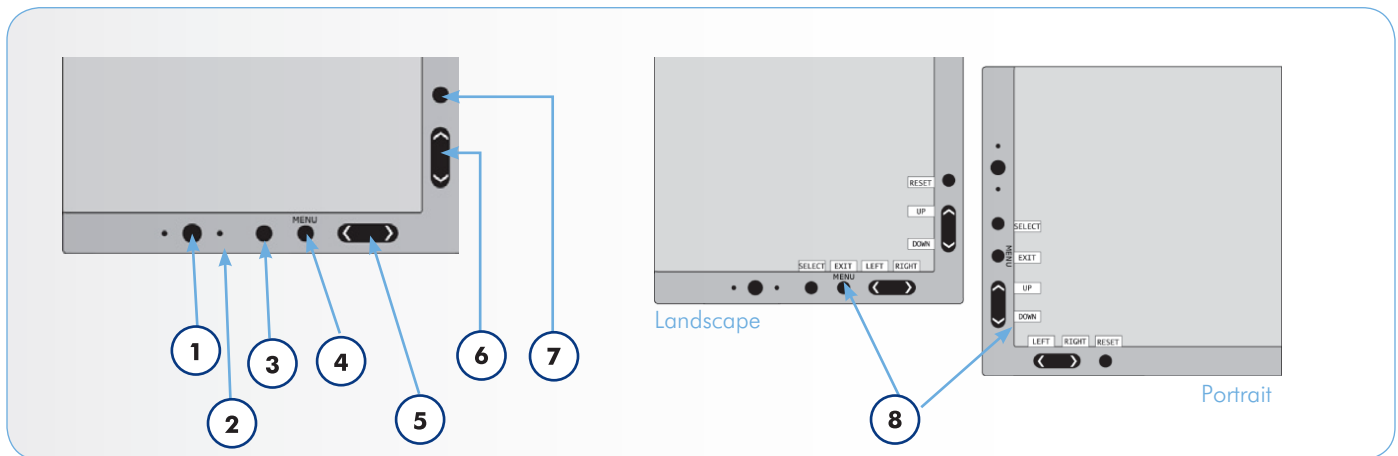

1 POWER	Turns the monitor on and off.
2 LED	Indicates that the power is on via the blue LED.
3 INPUT/SELECT	Enters the OSD Control menu and submenus. Changes the input source when not in the OSD Control menu.
4 MENU/EXIT	Access to the OSD menu. Exits the OSD Control menu and submenu.
5 LEFT/RIGHT*	Navigates to the left or right through the OSD Control menu. You can adjust the brightness directly (HotKey function ON), while the OSD menu is off.
6 UP/DOWN*	Navigates up or down through the OSD Control menu. You can adjust the contrast directly (HotKey function ON), while the OSD menu is off.
7 RESET	Resets the OSD back to factory settings. When pressed with the OSD inactive, you can select between PICTURE MODE and OVERSPEED.
8 KEY GUIDE	The Key Guide appears on screen when accessing the OSD Control menu. The Key Guide will rotate when the OSD Control menu is rotated.

* The functionality of the LEFT/RIGHT and UP/DOWN buttons is dependent on the orientation (Landscape/Portrait) of the OSD.



4.1. Brightness/Contrast Controls

Symbol	Menu title	Explanation
	BRIGHTNESS	Adjusts the overall image and background screen brightness. When PROGRAMMABLE is set by PICTURE MODE, the BRIGHTNESS cannot be adjusted.
	CONTRAST	Adjusts the image brightness in relation to the background.
	BLACK LEVEL	Adjusts the BLACK LEVEL.

4.2. Auto Adjust (Analog Input Only)

Symbol	Menu title	Explanation
		Automatically adjusts the IMAGE POSITION and H. SIZE settings and FINE settings.

4.3. Image Controls

Symbol	Menu title	Explanation
	LEFT/RIGHT	Controls Horizontal Image Position within the display area of the LCD.
	DOWN/UP	Controls Vertical Image Position within the display area of the LCD.
	H.SIZE (V.SIZE) (Analog Input Only)	<p>Adjusts the horizontal size. If the AUTO ADJUST function does not provide a satisfactory picture setting, further tuning can be performed using the H.SIZE (OR V.SIZE) function (dot clock). A Moiré test pattern may prove helpful in finding your ideal setting. Please be advised that this setting may alter the width of the picture. Use the LEFT/RIGHT Menu to center the image on the screen and note that the image should be homogeneous.</p> <div style="text-align: center;">  <p>H.SIZE value is incorrect H.SIZE value is improved H.SIZE value is correct</p> </div>
	FINE (Analog Input Only)	<p>Improves focus, clarity, and image stability. Use the FINE function to complement or enhance any adjustments the have been made with AUTO ADJUST and H.SIZE (OR V.SIZE). A Moiré test pattern may prove helpful in finding your ideal setting. The image should be homogeneous.</p> <div style="text-align: center;">  <p>FINE value is incorrect FINE value is correct</p> </div>
	AUTO FINE (Analog Input Only)	Automatically adjusts the FINE setting to compensate for changes in the signal condition. This function makes adjustments periodically, approximately every 33 minutes, or when a change in signal timing is detected.
	EXPANSION	<p>Sets the zoom.</p> <p>FULL: The image is expanded to 1920 x 1200 regardless of the resolution.</p> <p>ASPECT: The image is expanded without changing the aspect ratio.</p> <p>OFF: The image is not expanded.</p> <p>CUSTOM: Refer to 4.9. Advanced Menu Functions for detailed instructions.</p>

4.4. Color Control Systems

Symbol	Menu title	Explanation
	For presets 1, 2, 3 and 5, the following levels can be adjusted:	
	TEMPERATURE	Adjusts the white temperature. A lower color temperature will veer toward red while a higher color temperature will appear more blue.
	WHITE (White Balance):	If TEMPERATURE requires further adjustment, the individual R/G/B levels of the white point can be adjusted. To adjust them, use CUSTOM as your TEMPERATURE selection.
	HUE	Adjusts the hue of each color*. Use color bars to view the change in color with each adjustment.
	SATURATION	Adjusts the depth of each color*. Press the RIGHT button and the color vividness increases.
	OFFSET	Adjusts the brightness of each color*. Press the RIGHT button and the color brightness increases.
	sRGB	Standard color space that is device independent. This preset approximates the color gamut of the most common computer displays and peripherals. This preset is not adjustable via the OSD.
	NATIVE	Default Color temperature of the LCD Module without calibration (Not adjustable).
	PROGRAMMABLE	The color tone set by application software such as the LaCie blue eye pro.
	*RED, YELLOW, GREEN, CYAN, BLUE and MAGENTA	

TECHNICAL NOTE: To reset a poor image, turn on the monitor by using the front power button while simultaneously holding the RESET and SELECT buttons.

4.5. Tools

Symbol	Menu title	Explanation
	SHARPNESS	This function digitally maintains crisp images with all signal timings. It adjusts continuously to set images as distinct or as soft as you prefer. It may be set independently by different timings.
	DVI SELECTION	<p>This function selects the DVI input mode (DVI-I). When the DVI selection has been changed, the computer has to be restarted.</p> <p>AUTO By using the D-SUB to DVI-A cable, the DVI SELECTION is ANALOG. By using the DVI-D to DVI-D cable, the DVI SELECTION is DIGITAL.</p> <p>DIGITAL DVI digital input is available.</p> <p>ANALOG DVI analog input is available.</p>
	EDID EXTENSION (Digital Input Only)	<p>Selects the type of input to be used with EDID EXTENSION.</p> <p>NORMAL: When a PC or other computer equipment is connected, select NORMAL. ENHANCED: When a DVD player or other type of high definition device is connected, select ENHANCED.</p> <p>When EDID EXTENSION has been changed, the connected equipment must be restarted.</p>

TECHNICAL NOTE: When operating a Mac with a digital output, make certain that the DVI Input mode is set to DIGITAL in DVI SELECTION of the OSD. Press the SELECT button, then the CONTROL button when the DVI signal cable is connected to the DVI-I connector (DVI-I) of the monitor. The Mac may not turn on properly if the signal is not set on the monitor.

TECHNICAL NOTE: Interlaced signals (480i, 576i, 1080i) are not supported. Please consult the User Manual included with your playback device for assistance and detailed information.

TECHNICAL NOTE: DVI SELECTION may not operate correctly on a PC with certain video boards, or when a second video signal is received by the monitor.

Symbol	Menu title	Explanation
	VIDEO DETECT	<p>Selects the method of video detection when more than one computer is connected.</p> <p>FIRST The video input must be switched to FIRST mode. When the primary video input signal is lost, the monitor searches for a secondary signal from the alternate video input port. If a video signal is present, the monitor will automatically switch to the active source. The monitor will not look for other video signals while the primary video source is present.</p> <p>LAST The video input must be switched to LAST mode. No matter if a video source is playing in the primary video port, the monitor will switch signals if video is present in the alternate, or secondary port.</p> <p>NONE The monitor will not search the alternate video input port unless the port has been turned on.</p>
	OFF TIMER	<p>The monitor will automatically power down after a preset period of use. Before powering off, a message will appear on the screen asking if the user wants to delay the shut off time by 60 minutes. Press any OSD button to accept the delay. To adjust the preset period of time, select ON, then press SELECT and LEFT or RIGHT.</p>
	UNIFORMITY	<p>Electronically compensates for the slight variations in the white uniformity level, as well as for deviations in color that may occur throughout the display area of the screen. These variations are characteristic of LCD panel technology. This function improves the color and evens out the luminance uniformity of the display. Using the UNIFORMITY feature reduces the overall peak luminance of the display. If greater luminance is desired over the uniform performance of the display, then UNIFORMITY should be turned off.</p>
	POWER MANAGER	<p>The Power Manager has three settings:</p> <p>OFF Monitor does not go into power save mode when the input signal is lost.</p> <p>STANDARD Monitor enters power save mode automatically when the input signal is lost.</p> <p>OPTION Monitor enters power save mode automatically when the amount of surrounding light goes below the level that is determined by the user. The level can be adjusted in Tag7 of the 4.9. Advanced Menu Functions. When in POWER MANAGER, the LED on the front of the monitor blinks amber. While in POWER MANAGER, push any of the front buttons, except for POWER and SELECT, to return to normal. When the amount of surrounding light returns to standard levels, the monitor will automatically return to normal mode.</p>

4.6. Menu Tools

Symbol	Menu title	Explanation
	LANGUAGE	OSD Control menus are available in eight languages.
	OSD LEFT/RIGHT	You can choose where you would like the OSD Control image to appear on your screen. Selecting OSD Location allows you to manually adjust the position of the OSD Control menu Left or Right.
	OSD DOWN/UP	You can choose where you would like the OSD Control image to appear on your screen. Selecting OSD Location allows you to manually adjust the position of the OSD Control menu Down or Up.
	OSD TURN OFF	The OSD Control menu will stay on as long as it is use. In the OSD TURN OFF submenu, you can select how long the monitor waits after the last touch of a button to shut off the OSD Control menu. The preset choices are 10-120 seconds by 5 second steps.
	OSD LOCK OUT	<p>Lock out access to all or some of the OSD Control functions. When attempting to activate OSD controls while in the LOCK OUT mode, a screen will appear indicating the OSD Controls are locked. There are four types of OSD LOCK OUT:</p> <p>OSD LOCK OUT with BRIGHTNESS and CONTRAST control: To activate this OSD Lock Out function, press the SELECT and UP buttons simultaneously. To deactivate this OSD Lock Out, press the SELECT and UP buttons simultaneously while in the OSD menu. BRIGHTNESS and CONTRAST can be adjusted while in this lock out mode.</p> <p>OSD LOCK OUT with no control: To activate this OSD Lock Out function, press the SELECT and RIGHT buttons simultaneously. To deactivate this OSD Lock Out, press the SELECT and RIGHT buttons simultaneously while in the OSD menu. No controls can be adjusted while in the lock out mode.</p> <p>OSD LOCK OUT with BRIGHTNESS (only) control: To activate this OSD Lock Out function, press the SELECT, DOWN, and LEFT buttons simultaneously. To deactivate this OSD Lock Out, press the SELECT, DOWN, and LEFT buttons simultaneously while in the OSD menu. BRIGHTNESS can be adjusted while in this lock out mode.</p> <p>CUSTOM: Refer 4.9. Advanced Menu Functions.</p>

continued on the next page >>

Symbol	Menu title	Explanation
	RESOLUTION NOTIFIER	The optimal resolution is 1920 x 1200. If ON is selected, a message will appear on the screen after 30 seconds, notifying you that the resolution is not at 1920 x 1200.
	HOT KEY	When this function is set to ON, you can adjust BRIGHTNESS (LEFT or RIGHT buttons) and CONTRAST (DOWN or UP buttons) when the OSD menu is off. The standard OSD can be accessed with the EXIT button.
	FACTORY PRESET	Selecting Factory Preset allows you to reset all OSD control settings back to the factory settings. Individual settings can be reset by highlighting the control to be reset and pressing the RESET button.

4.7. Information

Symbol	Explanation
	Provides information about the current resolution being displayed, technical data, and the horizontal and vertical frequencies. Provides the model and serial numbers of your monitor.

4.8. OSD Warnings

Explanation

OSD Warning menus disappear with the EXIT button.

NO SIGNAL

Provides a warning when there is no Horizontal or Vertical Sync. After the power is turned on or when there is a change of input signal, the No Signal window will appear.

RESOLUTION NOTIFIER

This function gives a warning to use the optimal resolution. The RESOLUTION NOTIFIER window will open after power is turned on, when there is a change of input signal, or the video signal doesn't have proper resolution.

OUT OF RANGE

Recommends the optimal resolution and refresh rate. The OUT OF RANGE menu will open after the power is turned on, upon receiving a change of input signal, or the video signal does not have proper timing.

PORTRAIT WARNING

When the monitor is used in the portrait position, the brightness value will be reduced to 250 cd/m². If the PORTRAIT WARNING is ON, a message will appear on the screen for ten seconds.

LUMINANCE WARNING

When the backlight cannot display the desired luminance, a message will appear on the display. To avoid this, reduce the BRIGHTNESS level or set the AUTO LUMINANCE function to OFF ([4.9. Advanced Menu Functions](#), TAG1).

4.9. Advanced Menu Functions

To access the advanced menu:

1. Make certain your monitor is off.
2. Turn on your monitor by pushing the POWER and INPUT/SELECT buttons simultaneously for at least one second. The advanced menu will only appear once you press any of the control buttons (EXIT, LEFT, RIGHT, UP, DOWN) when the screen is active.
3. You will see the Advanced menu. This menu is larger than the normal OSD.
4. To make an adjustment, ensure that the Tag is highlighted, then press SELECT. To move to another Tag, press EXIT, then LEFT or RIGHT to highlight the next Tag.

To exit the advanced menu, turn off and restart your monitor by using the POWER button alone.

TECHNICAL NOTE: It is possible to change the DVI SELECTION, the POWER MANAGER, or the EDID EXTENSION settings while the NO SIGNAL or OUT OF RANGE messages are displayed.

continued on the next page >>

Tag	Menu title	Explanation
Tag1	BRIGHTNESS	<p>Adjusts the overall image and screen background brightness. Press LEFT or RIGHT to adjust.</p> <p>When AUTO LUMINANCE is OFF or 2, the brightness level is adjusted/measured using percentage (%).</p> <p>When AUTO LUMINANCE is 1 or 3, the brightness level is adjusted/measured using cd/m². This is the “Estimated Brightness” level.</p> <p>The upper portion (higher settings) of the brightness level is adjusted using the backlight output. If a very low brightness level (low setting) is used, the contrast level may be reduced. The display will digitally compensate for low brightness level. If this occurs, the indicator on the OSD will turn magenta.</p> <p>When selecting PROGRAMMABLE from the PICTURE MODE menu (4.10. Using the Picture Mode Function), you cannot select BRIGHTNESS.</p>
	CONTRAST	Adjusts the image brightness and contrast in relation to the background. Press LEFT or RIGHT to adjust.
	AUTO CONTRAST (Analog Input Only)	Adjusts the image displayed for non-standard video inputs. Press SELECT to adjust. Any adjustment requires the image to have white portions.
	AUTO BLACK LEVEL (Analog Input Only)	Automatically adjusts the black level. Any adjustment requires the image to have black portions. Press SELECT to activate Auto Adjust.
	BLACK LEVEL	Allows you to manually adjust the black level. Press LEFT or RIGHT to adjust.
	AUTO LUMINANCE	Unavailable with this model.

Tag	Menu title	Explanation
Tag2	R-H.POSITION (Analog Input Only)	Adjusts the position of the red component of the image. Press LEFT or RIGHT to adjust.
	G-H.POSITION (Analog Input Only)	Adjusts the position of the green component of the image. Press LEFT or RIGHT to adjust.
	B-H.POSITION (Analog Input Only)	Adjusts the position of the blue component of the image. Press LEFT or RIGHT to adjust.
	R-FINE (Analog Input Only)	Adjusts the FINE setting of the red component of the image. Press LEFT or RIGHT to adjust.
	G-FINE (Analog Input Only)	Adjusts the FINE setting of the green component of the image. Press LEFT or RIGHT to adjust.
	B-FINE (Analog Input Only)	Adjusts the FINE setting of the blue component of the image. Press LEFT or RIGHT to adjust.
	R-SHARPNESS (Analog Input Only)	Adjusts the FINE setting of the blue component of the image. Press LEFT or RIGHT to adjust.

Tag	Menu title	Explanation																			
Tag2	G-SHARPNESS (Analog Input Only)	Adjusts the sharpness of the green component of the image. Press LEFT or RIGHT to adjust.																			
	B-SHARPNESS (Analog Input Only)	Adjusts the sharpness of the blue component of the image. Press LEFT or RIGHT to adjust.																			
	DVI Long Cable (Digital Input Only)	Compensates for image degradation caused by using a long DVI cable. There are 4 possible settings, with "0" being the lowest level of compensation and "3" being the highest level. The default setting is "1".																			
Tag3	AUTO ADJUST (Analog Input Only)	Automatically adjusts the Image Position, H.Size settings, and Fine settings. Press SELECT to activate AUTO ADJUST.																			
	SIGNAL ADJUST (Analog Input Only)	Determines when the AUTO ADJUST is activated. The choices are SIMPLE and FULL. Press LEFT or RIGHT to select. <table border="1" data-bbox="533 794 1334 967"> <thead> <tr> <th></th> <th>H-size, Fine, H/V Position</th> <th>Contrast</th> </tr> </thead> <tbody> <tr> <td>SIMPLE</td> <td><input type="radio"/></td> <td>X</td> </tr> <tr> <td>FULL</td> <td><input type="radio"/></td> <td><input type="radio"/></td> </tr> </tbody> </table> <p><input type="radio"/> = AUTO ADJUST X = No AUTO ADJUST</p> <p>NOTE: Automatic Adjustment does not work at resolutions less than 800x600.</p>		H-size, Fine, H/V Position	Contrast	SIMPLE	<input type="radio"/>	X	FULL	<input type="radio"/>	<input type="radio"/>										
		H-size, Fine, H/V Position	Contrast																		
SIMPLE	<input type="radio"/>	X																			
FULL	<input type="radio"/>	<input type="radio"/>																			
AUTO ADJUST LEVEL (Analog Input Only)	Determines the level for AUTO ADJUST. The choices are SIMPLE, FULL, and DETAIL. Press LEFT or RIGHT to select. Refer to the below table. <table border="1" data-bbox="533 1203 1409 1466"> <thead> <tr> <th></th> <th>Size, Fine, Position</th> <th>Contrast</th> <th>Black level</th> <th>Time</th> </tr> </thead> <tbody> <tr> <td>SIMPLE</td> <td><input type="radio"/></td> <td>X</td> <td>X</td> <td>1 second</td> </tr> <tr> <td>FULL</td> <td><input type="radio"/></td> <td><input type="radio"/></td> <td>X</td> <td>1.5 seconds</td> </tr> <tr> <td>DETAIL</td> <td><input type="radio"/></td> <td><input type="radio"/></td> <td><input type="radio"/></td> <td>5 seconds</td> </tr> </tbody> </table> <p><input type="radio"/> = AUTO ADJUST X = No AUTO ADJUST</p>		Size, Fine, Position	Contrast	Black level	Time	SIMPLE	<input type="radio"/>	X	X	1 second	FULL	<input type="radio"/>	<input type="radio"/>	X	1.5 seconds	DETAIL	<input type="radio"/>	<input type="radio"/>	<input type="radio"/>	5 seconds
	Size, Fine, Position	Contrast	Black level	Time																	
SIMPLE	<input type="radio"/>	X	X	1 second																	
FULL	<input type="radio"/>	<input type="radio"/>	X	1.5 seconds																	
DETAIL	<input type="radio"/>	<input type="radio"/>	<input type="radio"/>	5 seconds																	

Tag	Menu title	Explanation
Tag3	A-NTAA SW (Analog Input Only)	The Advanced No Touch Auto Adjust function is able to recognize new signals even when the resolution and the refresh rate have not been changed. If several PCs are connected to the monitor, each transmitting very similar (or even the same) resolution and refresh rate signals, the monitor recognizes the new signal and automatically optimizes the picture. OFF: A-NTAA is disabled. ON: If a change in signal is detected, A-NTAA will adjust the monitor to the optimal settings. If no change in the signal is detected then A-NTAA does not activate. The screen will be blank while the monitor optimizes the signal.
Tag4	H. POSITION	Controls Horizontal Image Position within the display area of the LCD. Press LEFT or RIGHT to adjust.
	V. POSITION	Controls Vertical Image Position within the display area of the LCD. Press LEFT or RIGHT to adjust.
	H. SIZE (Analog Input Only)	Adjusts the horizontal size of the screen. If AUTO ADJUST does not give you a satisfactory picture setting, a further tuning can be performed using the H.SIZE (V.SIZE). A Moiré test pattern may assist in optimizing your settings. Please note that this function may alter the width of the picture. Use LEFT or RIGHT to center the image on the screen. The image should be homogeneous.
	FINE (Analog Input Only)	Adjusts the horizontal size of the screen. If AUTO ADJUST does not give you a satisfactory picture setting, a further tuning can be performed using the H.SIZE (V.SIZE). A Moiré test pattern may assist in optimizing your settings. Please note that this function may alter the width of the picture. Use LEFT or RIGHT to center the image on the screen. The image should be homogeneous.
	AUTO FINE (Analog Input Only)	This function automatically and periodically adjusts the FINE setting for changes in the condition of the signal. AUTO FINE adjusts approximately every 33 minutes or when a change in signal timing is detected.
	H. RESOLUTION	Adjusts the horizontal size by increasing or decreasing the setting. Press the RIGHT button to expand the width of the image on the screen. Press the LEFT button to narrow the width of the image on the screen.

Tag	Menu title	Explanation
Tag4	V. RESOLUTION	Adjusts the vertical size by increasing or decreasing the setting. Press the RIGHT button to expand the height of the image on the screen. Press the LEFT button to narrow the height of the image on the screen.
	EXPANSION	Sets the zoom method. FULL: The image is expanded to 1920 x 1200 regardless of the resolution. ASPECT: The image is expanded without changing the aspect ratio. OFF: The image is not expanded. CUSTOM: When CUSTOM is selected as the Expansion mode, you can adjust the H. ZOOM, V. ZOOM, and ZOOM POS.
	H.ZOOM (Available in Custom Expansion mode only)	The image is expanded from 1 to 3 times in the horizontal (H. EXPANSION) direction by 0.01 increments.
	V.ZOOM (Available in Custom Expansion mode only)	The image is expanded from 1 to 3 times in the vertical (V. EXPANSION) direction by 0.01 increments.
	ZOOM POS. (Available in Custom Expansion mode only)	Sets the point from which the screen will be expanded when either H.ZOOM or V.ZOOM are adjusted in Expansion mode. Options are CENTER and LEFT TOP. CENTER: H.ZOOM expands the image outward, from the center to the sides of the screen. V.ZOOM expands the image from the center to the top and bottom of the screen. LEFT TOP: Indicates the set point for image expansion (TOP in V. ZOOM, LEFT in H.ZOOM). The image will not expand past the TOP or the LEFT of the screen if the resolution does not fill the screen. The image can be expanded past the right and bottom edges of the screen.
Tag5	GAMMA SELECTION	Allows you to manually select the brightness level of the grayscale. There are five selections: NO CORRECTION, 2.2, OPTION, PROGRAMMABLE, and CUSTOM. NO CORRECTION: No Correction possible. 2.2: The value is fixed at 2.2. OPTION: Two choices offers two choices. 1: This setting is recommended for Video sources. Gray areas look much brighter than the NO CORRECTION setting. 2: The value near DICOM gamma is set up in a factory and the luminosity difference between gradations adjusts toward a legible state. PROGRAMMABLE: The brightness of the grayscale is adjusted to your preference using LaCie blue eye pro software. CUSTOM offers two options: Custom Value: The gamma value is selected from a rate of 0.5 to 4.0 by 0.1 steps. When the COLOR CONTROL is sRGB, the value is fixed at 2.2 and NOT ADJUSTABLE. Offset: The OFFSET digitally adjusts the black level after the signal is converted from analog to digital.

Tag	Menu title	Explanation
Tag6	COLOR CONTROL	<p>Color Control Systems: Seven preset color settings.</p> <p>For preset settings 1, 2, 3 and 5, the following levels can be adjusted:</p> <p>TEMPERATURE: Adjust the white temperature. A lower color temperature will make the screen reddish and a higher color temperature will make the screen bluish.</p> <p>WHITE (White Balance): Use only if TEMPERATURE needs further adjustment. Individual R/G/B levels of the white point can be adjusted. To adjust the R/G/B levels, CUSTOM must be showing as the TEMPERATURE selection.</p> <p>HUE: Adjusts the hue of each color*. The change in color will appear on screen and the menu color bars will show the amount of adjustment.</p> <p>SATURATION: Adjusts the color depth of each color*. Press the RIGHT button to increase the color vividness.</p> <p>OFFSET: Adjusts the color brightness of each color*. Press the RIGHT button and the color brightness increases.</p> <p>*RED, YELLOW, GREEN, CYAN, BLUE and MAGENTA.</p> <p>NATIVE, sRGB: Original color presented by the LCD panel that is not adjustable.</p> <p>PROGRAMMABLE: The color tone set up with the downloaded application software.</p> <p>NOTE: When sRGB, Adobe® RGB and PROGRAMMABLE are set by PICTURE MODE, you cannot select COLOR CONTROL.</p>
Tag7	SHARPNESS	This function digitally maintains crisp images with all timings. It adjusts continuously to set images as distinct or as soft as you prefer. It may be set independently by different timings.
	DVI SELECTION	<p>This function selects the DVI input mode. When the DVI selection has been changed, you must restart your computer. Press LEFT or RIGHT to select.</p> <p>AUTO: By using the DVI-D to DVI-D cable, the DVI SECTION is DIGITAL.</p> <p>By using the D-SUB to DVI-A cable, the DVI SECTION is ANALOG.</p> <p>DIGITAL: DVI digital input is available.</p> <p>ANALOG: DVI analog input is available.</p>
	EDID EXTENSION (Digital Input Only)	<p>Selects the type of input to be used with EDID EXTENSION.</p> <p>NORMAL: When a PC or other computer equipment is connected, select NORMAL.</p> <p>ENHANCED: When a DVD player or other type of high definition device is connected, select ENHANCED.</p> <p>NOTE: Interlaced signals (480i, 576i, 1080i) are not supported.</p> <p>When EDID EXTENSION has been changed, the connected equipment has to be restarted.</p>
	INPUT DEVICE (Digital Input Only)	Selects the HDCP Enabled input device, such as a media player (DVD) or a PC. A media player is the default setting and can be used when a PC is the playback device. If you do not see a signal, switch to PC for better results.

Tag	Menu title	Explanation
Tag7	VIDEO DETECT	<p>Selects the method of video detection when more than one computer is connected.</p> <p>FIRST The video input must be switched to FIRST mode. When the primary video input signal is lost, the monitor searches for a secondary signal from the alternate video input port. If a video signal is present, the monitor will automatically switch to the active source. The monitor will not look for other video signals while the primary video source is present.</p> <p>LAST The video input must be switched to LAST mode. No matter if a video source is playing in the primary video port, the monitor will switch signals if video is present in the alternate, or secondary port.</p> <p>NONE The monitor will not search the alternative video input port.</p>
	OFF TIMER	The monitor will automatically power down after a preset period of use. Before powering off, a message will appear on the screen asking if the user wants to delay the shut off time by 60 minutes. Press any OSD button to accept the delay.
	POWER MANAGER	<p>The POWER MANAGER has three settings:</p> <p>OFF Monitor does not go into power save mode when the input signal is lost.</p> <p>STANDARD Monitor enters power save mode automatically when the input signal is lost.</p> <p>OPTION Monitor enters power save mode automatically when the amount of surrounding light goes below the level that is determined by the user. When in power save mode, the LED on the front of the monitor blinks amber. While in power save mode, push any of the front buttons, except for POWER and SELECT, to return to normal. When the amount of surrounding light returns to standard levels, the monitor will automatically return to normal mode.</p>
	POWER MANAGER SETTING	Adjusts the luminance value for POWER MANAGER.
	OVERSPEED	Turns the OVERSPEED function on or off. OVERSPEED can reduce the blurring that may occur in some moving images.
	SIDE BORDER COLOR	For monitors that offer a wide aspect ratio, this adjusts the side black bars' color between black and white.
	LED BRIGHTNESS	Controls the brightness of the LED on the monitor.

Tag	Menu title	Explanation
Tag7	UNIFORMITY	This function electronically compensates for the slight variations in the white UNIFORMITY level as well as for deviations in color that may occur throughout the display area of the screen. These variations are characteristic of LCD panel technology. This function improves the color and evens out the luminance uniformity of the display. NOTE: Using the UNIFORMITY feature does reduce the overall peak luminance of the display. If greater luminance is desired over the uniform performance of the display, then UNIFORMITY should be turned off.
	UNIFORMITY LEVEL	You may select the level for UNIFORMITY adjustments.
Tag8	LANGUAGE	OSD Control menus are available in eight languages. Press LEFT or RIGHT to select.
	OSD H.POSITION	You can choose where you would like the OSD Control image to appear on your screen. Selecting OSD Location allows you to manually adjust the position of the OSD Control menu LEFT or RIGHT.
	OSD V. POSITION	You can choose where you would like the OSD Control image to appear on your screen. Selecting OSD Location allows you to manually adjust the position of the OSD Control menu UP or DOWN.
	OSD TURN OFF	The OSD Control menu will stay on as long as it is in use. Select how long the monitor waits after the last touch of a button to shut off the OSD control menu. The preset choices are 10-120 seconds by five seconds steps.
	SIGNAL INFORMATION	SIGNAL INFORMATION can be displayed in the corner of the screen. SIGNAL INFORMATION is either ON or OFF.
	RESOLUTION NOTIFIER	The optimal resolution is 1920 x 1200. If ON is selected, a message will appear on the screen after 30 seconds, notifying you that the resolution is not set to 1920 x 1200. Press LEFT or RIGHT to select.
	HOT KEY	When this function is set to ON, you can adjust BRIGHTNESS (LEFT or RIGHT buttons) and CONTRAST (DOWN or UP buttons) when the OSD menu is off.
	FACTORY PRESET	Selecting Factory Preset allows you to reset all OSD control settings back to the factory settings. Highlighting the control to be reset and pressing the RESET button can reset individual settings.

Tag	Menu title	Explanation
Tag8	OSD LOCK OUT	<p>Lock out access to all or some of the OSD Control functions. When attempting to activate OSD controls while in the LOCK OUT mode, a screen will appear indicating the OSD Controls are locked. There are four types of OSD LOCK OUT:</p> <p>OSD LOCK OUT with BRIGHTNESS and CONTRAST control: To activate this OSD Lock Out function, press the SELECT and UP buttons simultaneously. To deactivate this OSD Lock Out, press the SELECT and UP buttons simultaneously while in the OSD menu. BRIGHTNESS and CONTRAST can be adjusted while in this lock out mode.</p> <p>OSD LOCK OUT with no control: To activate this OSD Lock Out function, press the SELECT and RIGHT buttons simultaneously. To deactivate this OSD Lock Out, press the SELECT and RIGHT buttons simultaneously while in the OSD menu. No controls can be adjusted while in the lock out mode.</p> <p>OSD LOCK OUT with BRIGHTNESS (only) control: To activate this OSD Lock Out function, press the SELECT, DOWN, and LEFT buttons simultaneously. To deactivate this OSD Lock Out, press the SELECT, DOWN, and LEFT buttons simultaneously while in the OSD menu. BRIGHTNESS can be adjusted while in this lock out mode.</p> <p>CUSTOM: Press RESET and EXIT to enter the CUSTOM Menu. Select ENABLE or DISABLE for POWER KEY, INPUT SEL, HOT KEY (BRIGHTNESS/CONTRAST), WARNING (RESOLUTION NOTIFIER/OSD LOCK OUT). To Deactivate OSD LOCK OUT, press RESET and EXIT to bring up the LOCK OUT warning. Press SELECT, SELECT, <, >, <, >, EXIT.</p>
Tag9	OSD ROTATION	<p>AUTO: The OSD rotates automatically with the monitor. OSD ROTATION is set to AUTO by default.</p> <p>LANDSCAPE: Displays the OSD with landscape mode.</p> <p>PORTRAIT: Displays the OSD with portrait mode.</p>
	IMAGE ROTATION	<p>AUTO: The display image automatically rotates according to the orientation of the OSD. If AUTO is selected in the OSD ROTATION menu, the display image rotates according to the orientation of the monitor.</p> <p>OFF: The display image is not rotated. IMAGE ROTATION is set to OFF by default.</p> <p>ON: The display image always rotates.</p>

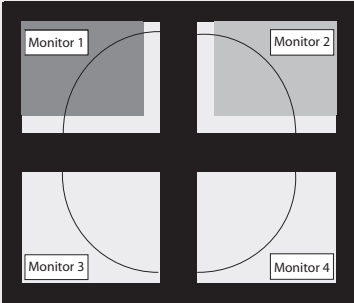
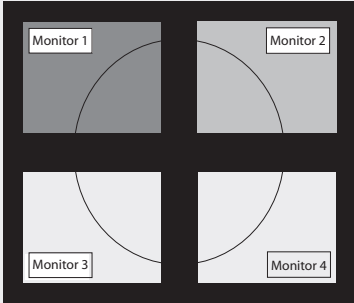
Tag	Menu title	Explanation
Tag9	PORTRAIT WARNING	When the monitor is used in the Portrait position, the brightness value will be reduced to 250 cd/m ² maximum. If the Portrait Warning is ON, a message will appear on the screen for ten seconds.
	DDC/CI	DDC/CI ENABLE/DISABLE: Turns on or off the two way communication and control of the monitor.
	INPUT SETTING	<p>Video Band Width (Analog Input Only): Used when there is too much noise on the screen. Press LEFT or RIGHT to select. The higher the number, the greater the correction.</p> <p>Sync Threshold (Analog input only): Adjusts the slice level of a synchronization signal. Press SELECT to move the adjustment menu. Adjusts the sensitivity of the separate or composite input signals. Try this option if the FINE adjustment does not successfully eliminate the noise.</p> <p>SOG Threshold (Analog input only): Adjusts the sensitivity of the Sync On Green input signals. Adjusts the slice level when separating synchronization from the Sync On Green signal input. Press LEFT or RIGHT to select.</p> <p>CLAMP POSITION: Operating your monitor at a non-standard timing may cause images to appear darker than normal or have color distortion. The CLAMP POSITION control will adjust images to their normal state.</p>
TagA	TILING	<p>A single screen displaying up to 25 monitors, TILING allows for viewing multiple signals. It will be able to divide up to five each on the Horizontal and the Vertical.</p> <p>The PC's output signal must be sent to a distribution amplifier to each monitor.</p> <p>H MONITORS: Select the number of horizontal displays.</p> <p>V MONITORS: Select the number of vertical displays.</p> <p>MONITOR NO.: Select a position to expand the screen.</p> <p>FRAME CUT: Works in tandem with TILING to compensate for the width of the tile bezels in order to accurately display the image.</p> <p>FRAME CUT with four monitors (black area shows monitor frames):</p> <div style="display: flex; justify-content: space-around; align-items: center;"> <div style="text-align: center;">  <p>FRAME CUT OFF</p> </div> <div style="text-align: center;">  <p>FRAME CUT ON</p> </div> </div>
TagB	INFORMATION	INFORMATION listed includes the current display resolution technical data, the horizontal and vertical frequencies, and the model and serial numbers.

4.10. Using the Picture Mode Function

Choose the Picture mode that is best suited to display the selected content. You may adjust the BRIGHTNESS, AUTO LUMINANCE and UNIFORMITY while in this mode. There are four Picture modes: STANDARD, sRGB, Adobe RGB, and PROGRAMMABLE.

- To access the Picture mode, press the RESET button while the OSD menu is not active.
- To select a mode, press the LEFT and RIGHT button.
- To exit the Picture mode, press the EXIT button.
- Scroll the menu using the UP and DOWN buttons and make all adjustments with the LEFT and RIGHT buttons.

TECHNICAL NOTE: When PROGRAMMABLE is selected, you cannot adjust the BRIGHTNESS or use AUTO LUMINANCE.

TECHNICAL NOTE: To make adjustments using Adobe RGB mode, choose sRGB mode then press SELECT.

Picture Mode	Purpose	Color Control	Gamma Selection (Advanced Menu)
STANDARD	Save the color settings according to your preference.	Settings made via the OSD COLOR CONTROL.	Settings made via the OSD GAMMA Selection.
sRGB	Save sRGB settings.	Fixed at 6500K for sRGB (OSD COLOR CONTROL adjustment not available).	Fixed to GAMMA for sRGB (OSD GAMMA adjustment not available).
Adobe RGB	Save Adobe RGB settings.	Fixed at 6500K for Adobe RGB (OSD COLOR CONTROL adjustment not available).	Fixed at 2.2 for Adobe RGB (OSD GAMMA adjustment not available).
PROGRAMMABLE	Save the LaCie blue eye pro settings. (BRIGHTNESS is disabled.)	Fixed at PROGRAMMABLE (OSD COLOR CONTROL adjustment not available).	Fixed at PROGRAMMABLE (OSD GAMMA adjustment not available).

4.11. Using the Auto Brightness Function

The brightness of the LCD screen can be set to increase or decrease depending on the amount of ambient light in the room. If the room is bright, the monitor becomes correspondingly bright. If the room is dim, then the monitor will dim accordingly. The purpose of this function is to make the viewing experience more comfortable to the eye in a variety of lighting conditions.

The Auto Brightness function is set to OFF by default. When AUTO LUMINANCE is ON, this function is disabled.

Setup: Select the brightness range

Use the following procedure to select the Brightness Range that the monitor will use when the AUTO BRIGHTNESS function is activated.

1. Set the BRIGHT level. This is the brightness level that the monitor will go to when the ambient light level is at its peak. Make sure the room is at its brightest when setting this level. Select "1" in the AUTO BRIGHTNESS menu (Fig. 21). Then use the front buttons to move the cursor up to the BRIGHTNESS setting. Choose the desired BRIGHTNESS level (Fig. 22).
2. Set the DARK level. This is the lowest level of brightness that the monitor will go reach when the ambient light level is low. Make sure the room is at its darkest when setting this level. Then use the front buttons to move the cursor up to the BRIGHTNESS setting. Choose the desired brightness level (Fig. 23).

IMPORTANT INFO: To access the AUTO BRIGHTNESS function, you must first access the Advanced OSD mode, TAG1 (4.9. Advanced Menu Functions).

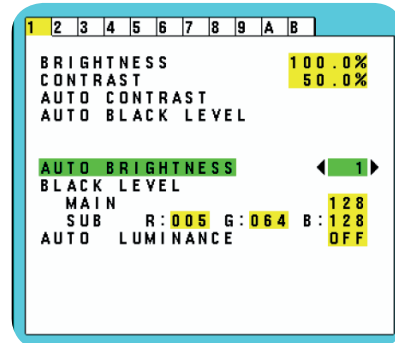

Fig. 21

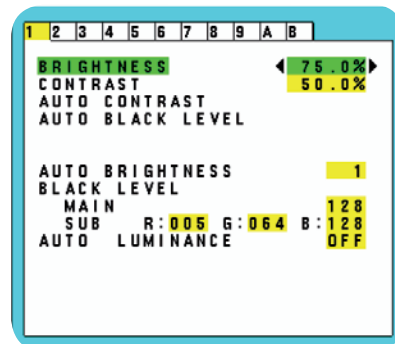

Fig. 22

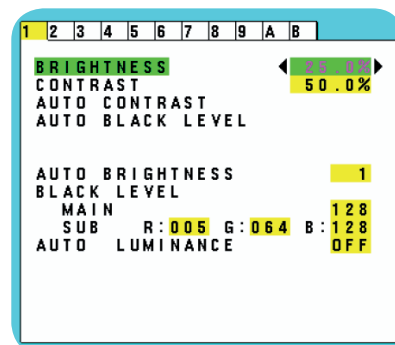

Fig. 23

When the AUTO BRIGHTNESS function is enabled, the BRIGHTNESS level of the screen adjusts automatically according to the lighting conditions of the room (Fig. 24).

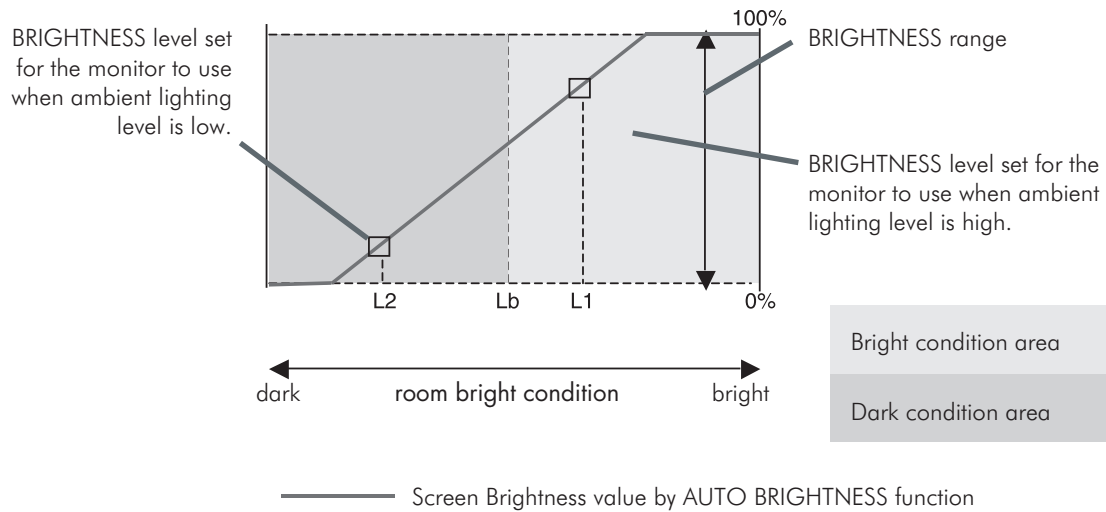

Fig. 24

Lb = Border between bright and dim lighting conditions; set at the factory

L1 = BRIGHTNESS level set for the monitor to use when ambient lighting level is high ($L1 > Lb$)

L2 = BRIGHTNESS level set for the monitor to use when ambient lighting level is low ($L2 < Lb$)

L1 and L2 = Brightness levels set by the user to compensate for changes in ambient lighting

5. Troubleshooting

In the event that your LaCie 500 Series LCD Monitor is not working correctly, please refer to the following checklist to aid in determining how to fix the problem. Additional tips are regularly updated on the FAQ page published on our website: www.lacie.com.

If you need further assistance, please contact your LaCie reseller or LaCie Technical Support (6. [Contacting Customer Support](#)).

Manual Updates

LaCie is constantly striving to give you the most up-to-date, comprehensive User Manuals available on the market. It is our goal to provide you with a friendly, easy-to-use format that will help you quickly install and utilize the many functions of your new device.

If your manual does not reflect the configurations of the product that you purchased, please check our website for the most current version available.

Problem	Solution
No picture.	<ul style="list-style-type: none"> ❖ The signal cable should be completely connected to the display card/computer. ❖ The display card should be completely seated in its slot. ❖ Check the Vacation Switch should be in the ON position. ❖ The Front Power Switch and the computer power switch should be in the ON positions. ❖ Check to make sure that a supported mode has been selected on the display card or system being used. (Please the consult display card or system manuals to change the graphics mode.) ❖ Check the monitor and your display card with respect to compatibility and recommended settings. ❖ Ensure the DVI input mode is set to DIGITAL when the Mac digital output is connected to the DVI-I connector. ❖ Check the signal cable connector for bent or pushed-in pins. ❖ Check the signal input, "DVI-D, DVI-I or DSub". ❖ When using a DVD player or any other type of high definition device, please do not use interlaced signals. If the monitor detects an interlaced signal, an OSD warning will appear. If this OSD warning appears, please do the following: press the RESET and EXIT buttons simultaneously, to temporarily show the image coming from the high definition device. While the image is visible, change the signal of the device from interlaced to progressive (non-interlaced). Consult the User Manual included with the device for detailed information on changing the signal from interlaced to progressive.
Power Button does not respond.	<ul style="list-style-type: none"> ❖ Unplug the power cord of the monitor from the AC outlet to turn off and reset the monitor. ❖ Check the Vacation Switch on the left side of the monitor.
LED on monitor is not lit.	The Power Switch should be in the ON position and the power cord should be connected.

Problem	Solution
Image persistence	<p>Please be aware that LCD Technology may experience a phenomenon known as Image Persistence. Image persistence occurs when a residual or “ghost” image of a previous image remains visible on the screen. Unlike CRT monitors, LCD monitors’ image persistence is not permanent, but constant images being displayed for a long period of time should be avoided. To alleviate image persistence, turn off the monitor for as long as the previous image was displayed. For example, if an image was on the monitor for one hour and a residual image remains, the monitor should be turned off for one hour to erase the image.</p> <p>NOTE: As with all personal display devices, LaCie recommends displaying moving images and using a moving screen saver at regular intervals whenever the screen is idle or turning off the monitor when not in use.</p>
Message OUT OF RANGE is displayed (screen is either blank or shows rough images only)	<ul style="list-style-type: none"> ❖ Image is displayed only roughly (pixels are missing) and OSD warning OUT OF RANGE is displayed: Either signal clock or resolution is too high. Choose one of the supported modes. ❖ OSD warning OUT OF RANGE is displayed on a blank screen: Signal frequency is out of range. Choose one of the supported modes.
Image is unstable, unfocused, or swimming is apparent	<ul style="list-style-type: none"> ❖ The signal cable should be completely attached to the computer. ❖ Use the OSD Image Adjust controls to focus and adjust display by increasing or decreasing the Fine setting. When the display mode is changed, the OSD Image Adjust settings may need to be readjusted. ❖ Check the monitor and your display card with respect to compatibility and recommended signal timings. ❖ If your text is garbled, change the video mode to non-interlaced and use 60Hz refresh rate.
Display image is not sized properly	<ul style="list-style-type: none"> ❖ Use the OSD Image Adjust controls to increase or decrease the Coarse total. ❖ Check to make sure that a supported mode has been selected on the display card or system being used. (Please consult display card or system manual to change graphics mode.)
No Video	<ul style="list-style-type: none"> ❖ If no video is present on the screen, turn the Power button off and on again. ❖ Make certain the computer is not in a power-saving mode (touch the keyboard or mouse).
Picture is not as bright	<ul style="list-style-type: none"> ❖ Make sure UNIFORMITY is turned off.
Self Diagnosis	<ul style="list-style-type: none"> ❖ The LCD display is equipped with the ability to self diagnose abnormalities. When the LCD detects a problem, the LED on the front flashes in a pattern of long and short blinks, depending on the type of problem detected. ❖ If the LED detects a problem, please refer service to qualified personnel.

6. Contacting Customer Support

Before You Contact Customer Support

Read the User Manual and review the Troubleshooting section.

If your question is related to monitor calibration, please refer to the Troubleshooting section of the LaCie blue eye pro User Manual. Launch the LaCie blue eye pro application and verify that your monitor is plugged to the DVI connection in the "About" section. Then perform a monitor Calibration Report and have it ready when contacting Technical Support.

If you have asked yourself all of the pertinent questions in the trou-

bleshooting checklist, and you still cannot get your LaCie monitor to work properly, please contact us. Before contacting us, make sure that you are in front of your computer and that you have the following information on hand:

Information	Where to Find Information
1. LaCie 500 Series serial number	Located on a sticker at the back of monitor or via the OSD (4.7. Information)
2. Macintosh/PC model	<p>Mac users: Click on the Apple icon in the menu bar and select About this Mac.</p> <p>Windows® users: Right click My Computer and select Properties > General.</p>
3. Operating system version	
4. Processor speed	
5. Computer memory	<p>Mac users: Click on the Apple icon in the Finder bar and select About this Mac. Select More Info... The Apple System Profiler will launch and list your internal and external peripherals.</p> <p>Windows users: Right click My Computer and select Properties > Hardware.</p>
6. The brands and models of other internal and external peripherals installed on my computer	

6.1. LaCie Technical Support Contacts

LaCie Asia Contact us at: http://www.lacie.com/asia/contact/	LaCie Australia Contact us at: http://www.lacie.com/au/contact/
LaCie Belgium Contact us at: http://www.lacie.com/be/contact/ (Français)	LaCie Canada Contact us at: http://www.lacie.com/caen/contact/ (English)
LaCie Denmark Contact us at: http://www.lacie.com/dk/contact	LaCie Finland Contact us at: http://www.lacie.com/fi/contact/
LaCie France Contact us at: http://www.lacie.com/fr/contact/	LaCie Germany Contact us at: http://www.lacie.com/de/contact/
LaCie Italy Contact us at: http://www.lacie.com/it/contact/	Japan - ELECOM CO. LTD Contact us at: http://www.lacie.com/jp
LaCie Netherlands Contact us at: http://www.lacie.com/nl/contact/	LaCie Norway Contact us at: http://www.lacie.com/no/contact/
LaCie Spain Contact us at: http://www.lacie.com/es/contact/	LaCie Sweden Contact us at: http://www.lacie.com/se/contact
LaCie Switzerland Contact us at: http://www.lacie.com/chfr/contact/ (Français)	LaCie United Kingdom Contact us at: http://www.lacie.com/uk/support/request/
LaCie Ireland Contact us at: http://www.lacie.com/ie/contact/	LaCie USA Contact us at: http://www.lacie.com/contact/
LaCie International Contact us at: http://www.lacie.com/intl/contact/	

7. Warranty Information

LaCie warrants your monitor against any defect in material and workmanship, under normal use, for the period designated on your warranty certificate. In the event this product is found to be defective within the warranty period, LaCie will, at its option, repair or replace the defective drive. This warranty is void if:

- ❖ The monitor was operated/stored in abnormal use or maintenance conditions;
- ❖ The monitor is repaired, modified, or altered, unless such repair, modification or alteration is expressly authorized in writing by LaCie;
- ❖ The monitor was subjected to abuse, neglect, lightning strike, electrical fault, improper packaging or accident;
- ❖ The monitor was installed improperly;
- ❖ The serial number of the monitor is defaced or missing;
- ❖ The broken part is a replacement part such as a pickup tray, etc.
- ❖ The tamper seal on the monitor casing is broken.

LaCie will not, under any circumstances, be liable for direct, special, or consequential damages such as, but not limited to, damage or loss of property or equipment, loss of profits or revenues, cost of replacement goods, or expense or inconvenience caused by service interruptions.

Under no circumstances will any person be entitled to any sum greater than the purchase price paid for the drive, monitor, or peripheral.

To obtain warranty service, call LaCie Technical Support. You will be asked to provide your LaCie product's serial number, and you may be asked to furnish proof of purchase to confirm that the monitor is still under warranty.

All monitors returned to LaCie must be securely packaged in their original box and shipped with postage prepaid.

IMPORTANT INFO: Register online for free technical support:
www.lacie.com/register
